

RV Series Rupture Disc Unit



MAXIMUM ALLOWABLE WORKING PRESSURES

The pre-set non-adjustable Rupture Disc burst pressure is indicated on the Disc manufacturer's metal ID tag. The standard Rupture Disc burst pressure is 1800 psig at 70 °F (12.4 MPa at 21 °C).

A stainless steel wire is provided with the Valve for the purpose of attaching the Rupture Disc manufacturer's ID Tag to the Valve,

Always consult your authorized Parker representative if question arise.

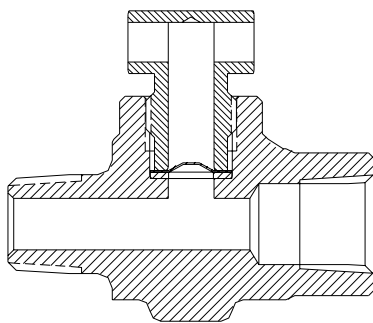

Figure 1: RV Series Rupture Disc Unit Cross Sectional View

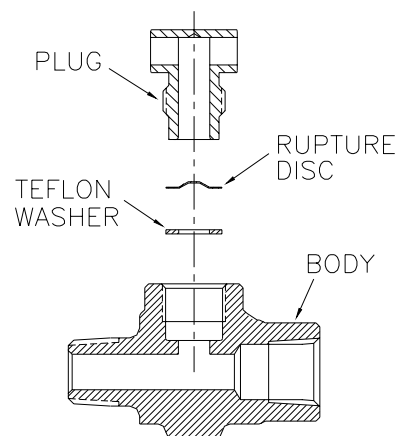

Figure 2: RV Series Rupture Disc Unit Exploded View

RUPTURE DISK USE

USERS SHOULD READ AND THOROUGHLY UNDERSTAND THESE INSTRUCTIONS BEFORE INSTALLING RUPTURE DISCS. THESE INSTRUCTIONS DO NOT PURPORT ALL OF THE SAFETY FACTORS ASSOCIATED WITH THE RUPTURE DISC'S USE IN SERVICE. IT IS THE RESPONSIBILITY OF THE USER TO ESTABLISH APPROPRIATE SAFETY, HEALTH, AND TRAINING MEASURES FOR THEIR PERSONNEL INSTALLING, SERVICING, OR WORKING IN AN AREA WHERE RUPTURE DISC ASSEMBLIES ARE IN USE.

IT IS THE USER'S RESPONSIBILITY FOR DESIGN OF ADEQUATE VENTING AND INSTALLATION OF ADEQUATE VENT PIPING OR DIRECTIONAL FLOW AFTER RUPTURE OCCURS WITH THE RUPTURE DISC AS INTENDED. LOCATE RUPTURE DISC WHERE PEOPLE OR PROPERTY WILL NOT BE EXPOSED TO THE SYSTEM DISCHARGE IN CASE OF RUPTURE. VENT TOXIC OR FLAMMABLE FUMES OR LIQUIDS TO A SAFE LOCATION TO PREVENT PERSONAL INJURY OR PROPERTY DAMAGE.

IT IS THE USER'S RESPONSIBILITY TO SPECIFY THE BURST PRESSURE RATING OF A RUPTURE DISC AT A COINCIDENT TEMPERATURE AT WHICH THE RUPTURE DISC IS TO BE USED. A RUPTURE DISC IS A TEMPERATURE SENSITIVE DEVICE. THE BURST PRESSURE OF THE RUPTURE DISC IS DIRECTLY AFFECTED BY ITS EXPOSURE TO THE COINCIDENT TEMPERATURE. GENERALLY, AS THE TEMPERATURE AT THE RUPTURE DISC INCREASES, THE BURST PRESSURE DECREASES; INVERSELY, AS THE TEMPERATURE AT THE RUPTURE DISC DECREASES, THE BURST PRESSURE MAY INCREASE. FAILURE TO PROPERLY UTILIZE A RUPTURE DISC AT THE SPECIFIED COINCIDENT TEMPERATURE COULD CAUSE PREMATURE OR OVERPRESSURIZATION OF A SYSTEM.

THE INSTANTANEOUS RELEASE OF PRESSURE FROM THE RUPTURE DISC CAN CREATE VIOLENT NOISES DUE TO THE DISCHARGE AT SONIC VELOCITY. IT IS THE USER'S RESPONSIBILITY TO PROTECT AGAINST HEARING DAMAGE TO ANY BYSTANDERS.

PARTICLES MAY BE DISCHARGED WHEN THE RUPTURE DISC RUPTURES. THESE PARTICLES MAY BE PART OF THE RUPTURE DISC ITSELF, OR OTHER ENVIRONMENTAL MATTER IN THE SYSTEM. IT IS THE USER'S RESPONSIBILITY TO ASSURE THAT THESE PARTICLES ARE DIRECTED TO A SAFE AREA TO PREVENT PERSONAL INJURY OR PROPERTY DAMAGE.

THERE IS NO GUARANTEE OF RUPTURE DISC LIFE. SUCH LIFE SPAN IS AFFECTED BY CORROSION, CREEP AND FATIGUE, AND PHYSICAL DAMAGE. THESE CONDITIONS WILL DERATE THE RUPTURE DISC TO A LOWER SET PRESSURE. THE CUSTOMER AND/OR USER SHOULD BE PREPARED TO HANDLE A PREMATURE FAILURE OF THE RUPTURE DISC. THE MEDIA OR OTHER ENVIRONMENTAL CONDITIONS SHOULD NOT ALLOW ANY BUILDUP OR SOLIDIFICATION OF MEDIA TO OCCUR ON A RUPTURE DISC. THIS MAY INCREASE THE PRESSURE SETTING OF THE RUPTURE DISC.

PREVENTATIVE MAINTENANCE

1. REPLACE RUPTURE DISC EVERY YEAR UNDER NORMAL CONDITIONS. A MORE FREQUENT CHANGEOUT MAY BE NECESSARY DUE TO CORROSION, FATIGUE, TEMPERATURE, OR ADVERSE CONDITIONS. THESE FACTORS MUST BE EVALUATED BY THE USER THROUGH ACTUAL SERVICE EXPERIENCE.
2. IF THE RUPTURE DISC IS NOT REPLACED PERIODICALLY WHEN EXPOSED TO THESE CONDITIONS, PREMATURE FAILURE OF THE RUPTURE DISC MAY OCCUR, THEREBY DISCHARGING THE PROCESS MEDIA.
3. TO AVOID EXTENDED DOWNTIME, MAINTAIN THREE SPARE RUPTURE DISCS IN STOCK AT ALL TIMES. THE NUMBER OF SPARES REQUIRED ULTIMATELY WILL BE DETERMINED BY SERVICE CONDITIONS.

DISASSEMBLY

WARNING: MAKE CERTAIN THE SYSTEM IN WHICH THE VALVE IS INSTALLED IS DRAINED AND/OR EXHAUSTED OF ALL PRESSURE BEFORE STARTING VALVE REMOVAL OR DISASSEMBLY. FAILURE TO DO SO CAN CAUSE DEATH, PERSONAL INJURY AND PROPERTY DAMAGE.

1. Verify that the Rupture Disc Valve Maintenance Kit being used is appropriate for the Rupture Disc pressure rating and service requirements. Always contact your authorized Parker representative if any questions arise.
2. Remove and discard the manufacturer's ID Tag for the Rupture Disc which may be attached to the Valve.
3. Refer to Figure 2. Remove and discard the Rupture Disc Plug by turning counter-clockwise with an 11/16 inch hex wrench.
4. Remove and discard the Rupture Disc and Washer from the Rupture Disc chamber.

REASSEMBLY

1. Make certain all parts are free of dirt or other contamination before starting reassembly of the Valve.
2. Refer to the manufacturer's ID tag which accompanies the new Rupture Disc and PTFE Washer. Verify the burst pressure rating for the new Rupture Disc agrees with the desired burst pressure.
3. Refer to Figure 2. Locate the Rupture Disc chamber. Install the PTFE or optional Metal Washer in the Rupture Disc chamber in the Body.
4. Refer to Figure 1. Install the Rupture Disc in the Rupture Disc chamber in the Body.

NOTE: It is imperative the Washer be positioned flat and level in the Rupture Disc chamber. The Metal Washer must be positioned with the chamfer side down.

CAUTION: It is imperative the Rupture Disc be positioned such that the spherical dome faces outward and lays flat and level in the Rupture Disc chamber.

WARNING: It is recommended that the manufacturer's ID tag stay with the specific Rupture Disc Assembly used in any given Rupture Disc Valve.

5. Gently install the Plug in the Body until the Plug is hand-tight.
6. Secure the Body in an assembly fixture.
7. Torque the Plug in the Body by turning the Plug clockwise with an 11/16 inch hex socket torque wrench to 45 In-lbs.
8. A stainless steel wire is provided with the Valve maintenance kit for the purpose of attaching the Rupture Disc manufacturers' ID Tag to the Valve.

VALVE CONNECTOR MAKE-UP INSTRUCTIONS

MALE AND FEMALE PIPE PORTS

Wrench flats are provided on the Valve Body. It is recommended a smooth-jawed wrench or vise be used to grip the Valve Body.

1. On the male threaded part of the connection, apply a high quality pipe joint compound or PTFE tape made for this purpose. When PTFE tape is used, it is recommended two full turns of tape be applied. PTFE tape should not be overhanging or covering the first thread
2. Engage the Valve and the other component part together, until hand-tight.
3. With a proper wrench, holding both the Valve and the component part, continue to tighten to achieve a leak-tight joint.

ULTRASEAL CONNECTIONS

1. Insert the proper O-Ring into the UltraSeal fitting's O-Ring groove. Position the UltraSeal gland sealing face against the O-Ring, and then advance the Nut to a finger-tight position.
2. A positive seal is obtained by advancing the Nut no less than 1/4 turn from the finger-tight position. Proper UltraSeal make-up is achieved when a sharp rise in required application torque occurs, which indicates proper seal face contact and O-Ring seal compression into the UltraSeal groove.

VACUSEAL CONNECTIONS

1. A positive seal is obtained by advancing the Nut 1/8 turn from the finger-tight position.
2. A new gasket should be installed upon each fitting re-make to insure system pressure integrity.

TUBE FITTING CONNECTIONS

1. Insert the tube into the Valve port until the tube bottoms out in the Valve Body. Care should be exercised to insure the tube is properly aligned with the Valve Body and port.
2. Normal make-up for US Customary port sizes 1 thru 3 (1/16 thru 3/16 inch) and SI port sizes 2 thru 4 (2 thru 4 mm) is 3/4 turn from finger tight. Normal make-up for US Customary port sizes 4 thru 16 (1/4 thru 1 inch) and SI port sizes 5 thru 25 (5 thru 25 mm) is 1 1/4 turn from finger tight. For larger port sizes consult Parker Ferrule Presetting Tool Instructions.

PLEASE FOLLOW THE ABOVE DIRECTIONS FOR COUNTING THE NUMBER OF TURNS FOR PROPER FITTING MAKE-UP. DO NOT MAKE-UP TUBE FITTINGS BY TORQUE OR "FEEL". VARIABLES SUCH AS TUBING AND FITTING TOLERANCES, TUBE WALL THICKNESS, AND THE LUBRICITY OF NUT LUBRICANTS CAN RESULT IN AN IMPROPERLY ASSEMBLED TUBE FITTING CONNECTION.

A -Two ferrule A-LOK[®] compression port



Z -Single ferrule CPI[™] compression port



F -ANSI/ASME B1.20.1 Internal pipe threads



V -VacuSeal face seal port



Q -UltraSeal face seal port



M -ANSI/ASME B1.20.1 External pipe threads



WARNING

FAILURE OR IMPROPER SELECTION OR IMPROPER USE OF THE PRODUCTS AND/OR SYSTEMS DESCRIBED HEREIN OR RELATED ITEMS CAN CAUSE DEATH, PERSONAL INJURY AND PROPERTY DAMAGE.

This document and other information from Parker Hannifin Corporation, its subsidiaries and authorized distributors provide product and/or system options for further investigation by users having technical expertise. It is important that you analyze all aspects of your application and review the information concerning the product or system in the current product catalog. Due to the variety of operating conditions and applications for these products or systems, the user, through its own analysis and testing, is solely responsible for making the final selection of the products and systems and assuring that all performance, safety and warning requirements of the application are met.

The products described herein, including without limitation, product features, specifications, designs, availability and pricing, are subject to change by Parker Hannifin Corporation and its subsidiaries at any time without notice.

ALL PARKER VALVES MUST PASS A RIGID OPERATIONAL AND LEAKAGE TEST BEFORE LEAVING THE FACTORY. IT IS RECOMMENDED AFTER ANY REASSEMBLY, THE VALVE SHOULD BE TESTED BY THE USER FOR OPERATION AND LEAKAGE. IF THESE INSTRUCTIONS ARE NOT FULLY COMPLIED WITH, THE REPAIRED PRODUCT MAY FAIL AND CAUSE DAMAGE TO PROPERTY OR INJURY TO PERSONS. PARKER HANNIFIN CANNOT ASSUME RESPONSIBILITY FOR PERFORMANCE OF A CUSTOMER SERVICED VALVE.

